

Airborne™ Embedded Wireless Bridge Ethernet to 802.11b Wireless LAN (Module)

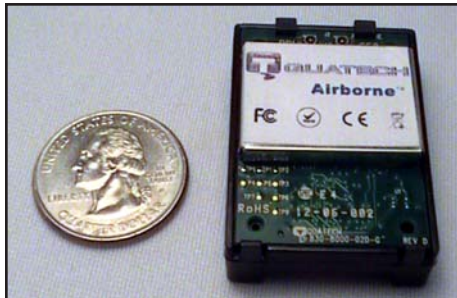

WLNb-ET-DP100 series
WLNb-ET-DP500 Enterprise series



programming of the module - only simple configuration is required using DPAC's HTML interface.

The Airborne™ modules have been designed to provide wireless LAN and Internet connectivity in these industries:

- transportation
- medical
- warehouse logistics
- POS
- industrial
- military
- scientific

Any system with an existing Ethernet port can be wirelessly enabled by connecting the Airborne Ethernet Bridge module directly to the output of its Ethernet PHY, maintaining current firmware and software while enhancing system functionality.

The Evaluation & Design Kit provides software and utilities that allow a developer to quickly and easily operate and evaluate the Bridge module.

Simple configuration, advanced security

Airborne™ is a line of highly integrated 802.11 modules. The wireless module includes a radio, a base-band processor, an application processor and software for a "drop-in" web-enabled Wi-Fi solution. Since there's no need to develop the software, or to develop the RF and communications expertise inhouse, OEM's can realize reduced product development costs and a quick time-to-market. Airborne™ modules provide instant LAN and Internet connectivity, and connect through standard ethernet interface to a wide variety of applications.

Applications

The extremely small footprint design makes Airborne™ easy to embed into new or existing designs. The module is interoperable with industry standard 802.11 LAN and Internet connectivity and provides advanced security standards such as WEP, WPA and EAP, to deliver a low cost infrastructure for connection to a LAN and to the Internet. The built-in TCP/IP stack, RTOS and application software provide embedded devices with instant LAN and Internet connectivity without special

KEY FEATURES

- Extended operating temperature range (-40°C to +85°C) and environmental specifications
- Advanced security: WEP (64 & 128 bit), WPA and 802.1x (LEAP) authentication
- Built-in web server enables drop-in LAN and Internet connectivity
- Highly integrated transparent 802.11b Wireless Ethernet Bridge
- Quick time to market and reduced development costs
- Integrated 10 base-T Ethernet PHY
- Integrated RTOS, TCP/IP Stack and CLI
- Reduces need for RF and communications expertise
- FCC Part 15 Class B Sub C Modular Approval
- RoHS compliant
- Five year warranty

Model Selection Guide

Model No.	Interface	WiFi	Security		
	10 Base-T Ethernet	802.11b	WEP (64 & 128 bit)	WPA	LEAP*
WLNb-ET-DP101	●	●	●	●	
WLNb-ET-DP501	●	●	●	●	●



For RoHS-compliant 802.11b products, add "-G" at end of model number.

*Web server not present with LEAP

Block Diagram

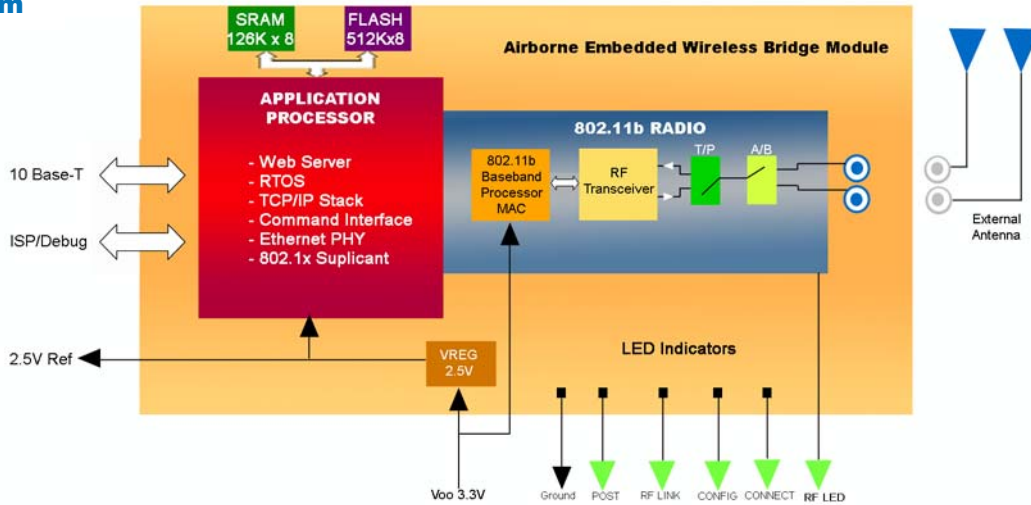

Mechanical Outline

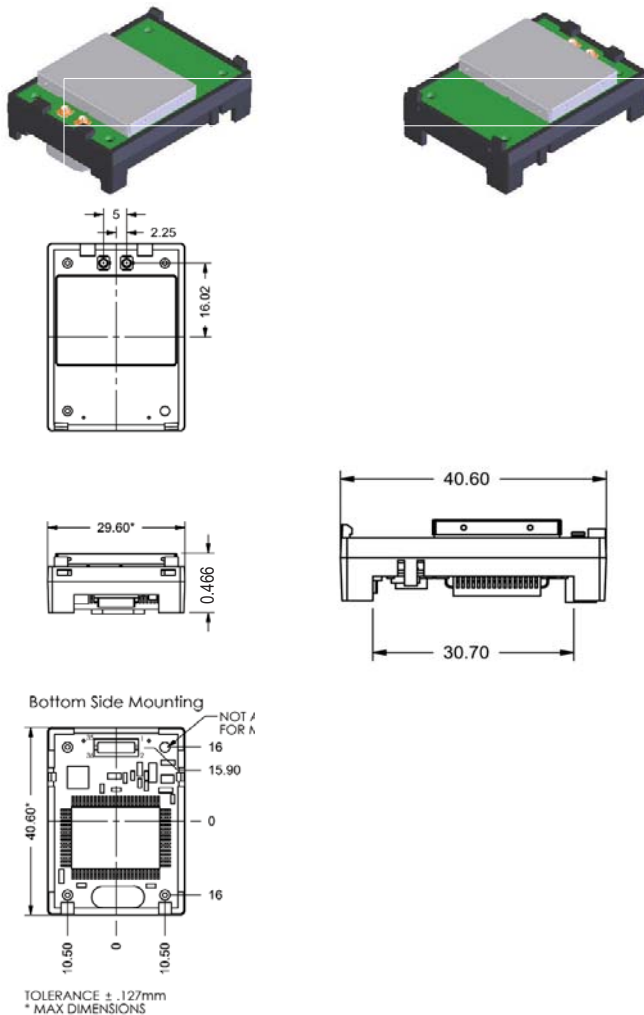

Specifications

Technology	IEEE 802.11b DSSS, WiFi compliant
Ethernet Interface	10 Base-T PHY, 10Mbps
Frequency	2.4 ~ 2.4835 GHz (US/Can/Japan/Europe) 2.474 ~ 2.497 GHz (Japan)
Modulation	DQPSK, DBPSK and CCK
Channels	USA/Canada: 11 channels Europe: 13 channels Japan: 14 channels France: 4 channels
Wireless Data Rate	11, 5.5, 2, 1 Mbps
MAC	CSMA/CA with ACK, RTS, CTS
Protocols	TCP/IP, ARP, ICMP, DHCP, DNS, HTTP
Data Transfer	UDAP Discovery TCP/IP, HTTP, UDP
RF Power	+15 dBm (typical) Approx. 32 mW
Sensitivity	-82dBm for 11Mbps -86dBm for 5.5 Mbps -88dBm for 2 Mbps -90dBm for 1 Mbps
Security	WEP (64 & 128 bit), WPA (PSK & TKIP), WPA with LEAP
Antenna	Supports diversity antennas, using U.FL coaxial connectors (50 Ohms)
Supply	3.3 VDC
Current Consumption	420mA - transmit mode (typical) 350mA - receive mode (typical) 75mA - sleep mode (typical)
Operating Temperature	-40°C - +85°C
Connector	Hirose 36 Pin HRS-DF12-36DS-0.5V
Agency Approvals	FCC Part 15 Class B Sub C Intentional Radiator Modular Approval Industry of Canada RoHS and WEEE compliant